

ITP100x40-Ø15 HL40

EAN 4031582329797

wielkern van aluminium met gegoten polyurethaan loopvlak, precisiekogellagers,

Technische data

Wieldiameter	100 mm
Bandbreedte	40 mm
Asgat-Ø	15 mm
Naaflengte	40 mm
Temperatuur	- 20 / + 60 °C
Dyn. draagvermogen	300 kg
Statisch draagvermogen	600 kg
Hardheid van de band	A 92 Shore

Rolweerstand	+	+	+	+	+
Verplaatsingsgeluid	+	+	+	+	+
Strepen	+	+	+	+	+
Roest bescherming	+	+	+	+	+

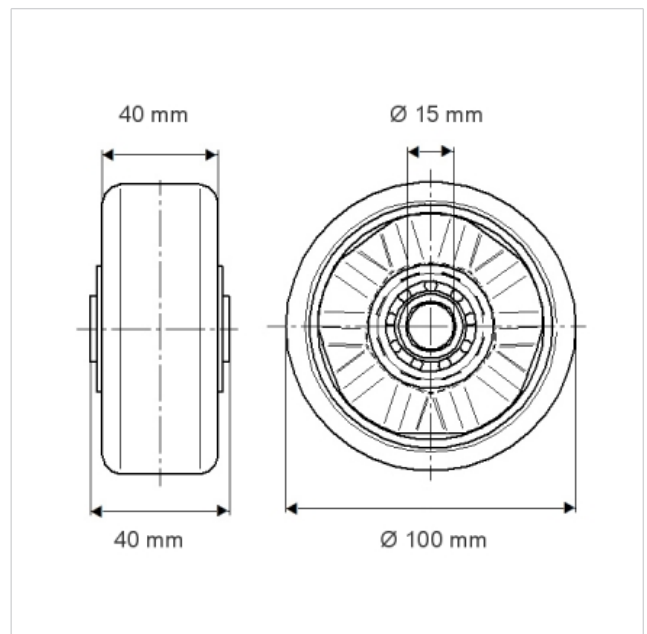



ITP100x40-Ø15 HL40

EAN 4031582329797

